



Storage and Installation of welded LL Hollow Metal Window Frames in Steel Studs

Introduction

This guide specification is intended to stress the necessary precautions and requirements for receipt, storage, handling and installation of lead lined hollow metal frames.

The proper performance of most products depends not only on how they are manufactured, but how they are installed. This is especially true of lead lined fixed hollow metal window frames. The installation of lead glass and frames demands care and skill. Care in manufacturing does not, in itself, guarantee satisfactory performance. Even the best designed and most carefully constructed frames, if incorrectly installed, may not function as intended.

Lead Lined Fixed Hollow metal window frames are fabricated in accordance with the shop drawings, approved by the architect or engineer in accordance with the information furnished to the lead lined hollow metal manufacturer.

We are a material supplier, not a subcontractor. We do not include the installation of our products in the building, but only shipment in good condition from the factory.

Should the General Contractor discover any error in the lead lined fixed hollow metal frames delivered to the job site, it is imperative that A&L be notified in writing and allowed sufficient time before initiating any corrective measure in the field, so that the manufacturer can participate in solving the problem. Failure to do so could result in the cancellation of the warranty and non-acceptance of any cost associated with repair as we must determine whether the fault lies with A&L or with some other party.

It is essential that material is properly stored prior to installation and skills are exercised in the setting of frames and hanging of doors.

Receiving and Storage of Material

A. Receiving

Upon delivery, the consignee responsible for receiving lead lined fixed hollow metal window frames shall thoroughly inspect for damage in a timely manner prior to forwarding or installing them. Crating and packing materials shall be removed for inspection and to promote air circulation. Any scratches or disfigurements caused in shipping or handling shall be promptly cleaned and touched up with a metal rust inhibitive primer.

Should damaged material be found, the consignee has the option of refusing delivery or to accept the material as damaged. For coordination purposes, A&L suggests that delivery should not be refused, but rather accepted as damaged. Any damaged items should be noted on the freight bill. Claims will not be honored by the freight carrier, unless the damaged items are noted on the freight bill at the



time of delivery. The consignee shall notify A&L in writing immediately of any item signed for as damaged. The consignee must telephone or write the local office of the freight carrier and request an inspection of the damage. This procedure will help to expedite the repair or replacement of the damaged items and the processing of the damage claim with the freight carrier.

B. On Site Storage

Proper storage of lead lined hollow metal frames at the construction site will help prevent damage to the primer coat of paint. Prime coated steel must be protected when exposed to the elements such as high humidity, salt air, rain, snow, etc.... Particular attention must, therefore, be given to steel products having a coat of factory applied primer. Primer is porous to properly receive and hold top coats. Water or moisture, in contact with primer coated steel will seep through to the steel. An electrolytic action then follows, resulting in corrosion and causing the paint film to lose adhesion. The presence of oxygen at the water-air interface behind the loosened paint film accelerates corrosive action and the prime coat further deteriorates.

Even when zinc coated steel is used to provide corrosion resistance, one week of product exposure to water, due to improper storage, can be equivalent to at least a year of outdoor exposure to the elements.

NOTE: Paint manufacturers advise that the primer should receive a finish coat of paint within 30 days of delivery. It is the responsibility of the General Contractor to sand, touch up and clean prime painted surfaces prior to finish painting in accordance with the finish paint manufacturer's instructions.

The following procedures shall always be observed in storing lead lined fixed hollow metal window frames at the job site:

1. Store all materials in a dry area, under cover. All products shall be stored where they will not be exposed to, or come in contact with the elements.
2. Do not use non-vented plastic or canvas. These materials create a humidity chamber, which promotes blistering and corrosion.
3. Store frames in an upright position with heads uppermost.
4. Place no more than 5 welded frames in a group. Small groups not only minimize the likelihood of damage due to excess handling, but also facilitate selection from the group for installation. In the case of multi-opening frames, no more than three units should be stored in a group, to avoid serious damage to the bottom most frame.
5. Place all material on planking or blocking at least 4 in. (100 mm) off the ground, 2 in. (50mm) off a paved area or the floor slab.
6. Provide at least 1/4 in. (6.4 mm) space between all units to permit air circulation.

Installation of Frames:

General

Lead lined fixed hollow metal window frames are checked at the factory to ensure that they are square and that no jamb twists have occurred during fabrication. The frames are loaded on the carrier by personnel experienced in frame packing.



In spite of our precautions, lead lined fixed hollow metal window frames can and sometimes do arrive at the job site with minor alignment deviations. Minor deviations from true form and alignment can be corrected by the contractor responsible for installation.

Prior to Installation

The installer shall perform the following prior to installation:

Frame shall be checked for correct size, swing, preps, fire rating and opening number prior to installation.

Installation Tolerances

During the setting of the frame, check and correct as necessary for opening width, opening height, squareness, alignment, twist and plumbness. Permissible frame product installation tolerances shall be maintained within the following limits:

- | | |
|-----------------|---|
| Opening width: | Measured horizontally from rabbet to rabbet at top, middle and bottom of frame; +/- 1/16 in. (1.5mm). |
| Opening height: | Measured vertically between the frame head rabbet and top of sill rabbet and horizontally between each jamb and across the head and sill; +/- 3/64 in. (1.2mm). |
| Squareness: | Measured at rabbet on both diagonal lines from head to sill 1/16 in. (1.5mm). |
| Alignment: | Measured at jambs on a horizontal line parallel to the plane of the face; not to exceed 1/16 in. (1.5mm). |
| Twist: | Measured at opposite face. Corners of jamb on parallel lines, perpendicular to the plane of the door rabbet. |
| Plumbness: | Measured at jambs on a perpendicular line from the head to the sill; not to exceed 1/16 in. (1.5mm). |

The tolerances shown provide a reasonable guideline for proper installation of fixed hollow metal window frames. However, it should be noted that the cumulative effect of the installation tolerances at or near their maximum levels could result in sufficient misalignment to prevent the glass from being installed properly. Installers should be careful not to create a tolerance buildup. Tolerance buildup occurs when several tolerances are at or near their maximums. Care should be taken to keep each of these tolerances as close to zero as possible.

NOTE: It is very important to use a plumb line to make sure the jambs are plumb.

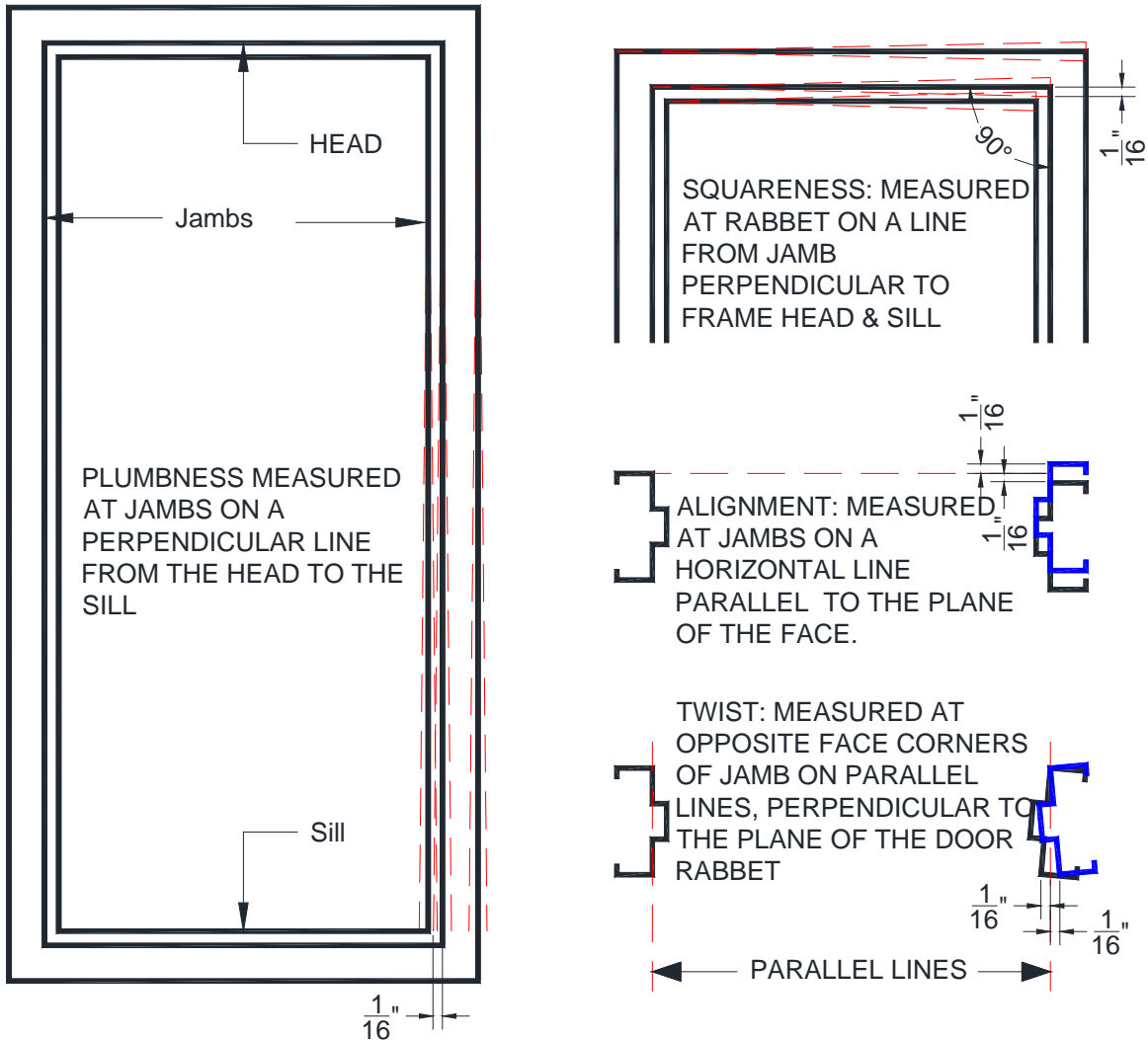

The installation contractor shall have a plumb bob, carpenter level and builder's square. Level the head by positioning the level to the head of the window rabbet. With builder's square, check frame for squareness and twist. Position square against jambs and head and sills at glass rabbet to check for square, adjust as required. Position square against door rabbet and project line perpendicular to the plane of the door rabbet, adjust as required.

Once the installer has ensured that the frame is in the correct position, anchor the jambs to the steel studs.

Jamb Anchors: Z shaped anchor is welded to frame rabbet inside the jamb. Steel studs are mechanically fastened to the exposed flange through the throat of the stud.



Position the vertical steel studs in the frame throat opening and horizontal steel studs in the head and sill in accordance with Architect's details. Attach the vertical steel studs to floor and ceiling runners and fasten to the steel stud anchors with mechanical fasteners.

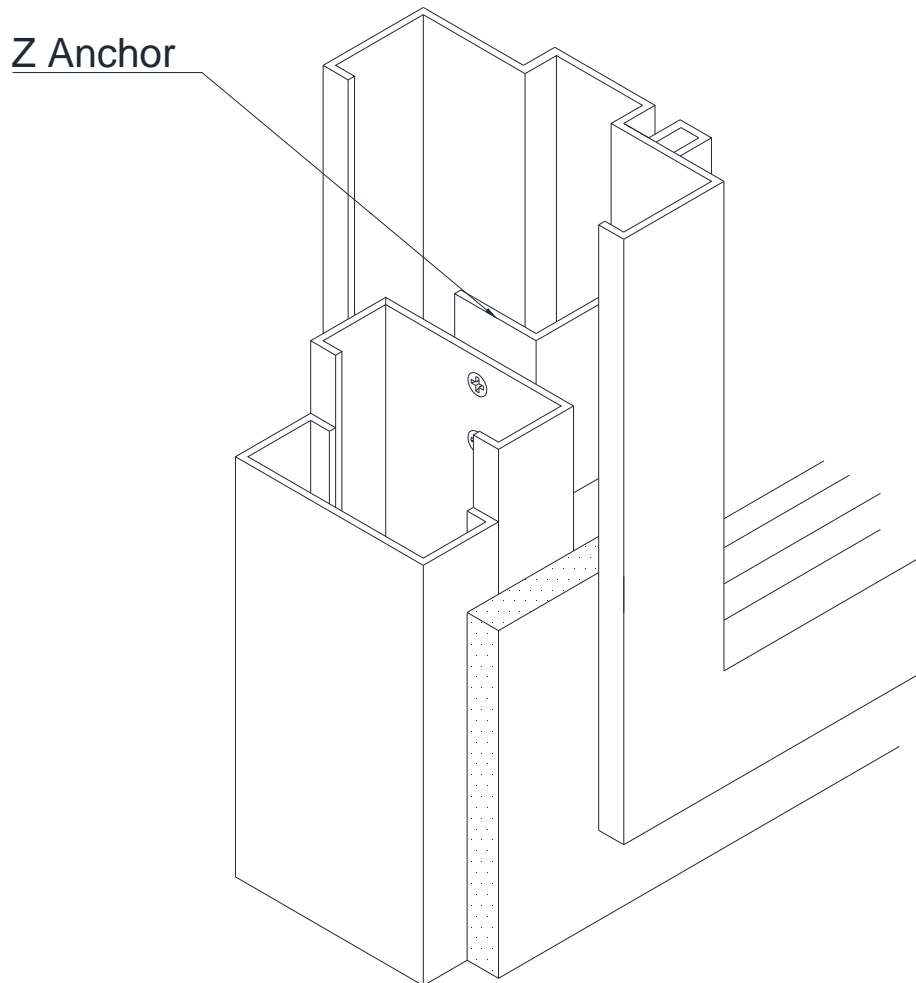

Proper frame anchoring is vitally important to the proper performance of the door opening. A variety of jamb wall anchors are available to suit the various types of wall construction. We are only covering anchors for fixed welded window frames with steel studs in this document.

Wall Construction: It is extremely important that the steel stud manufacturer's recommendation on thickness and general construction technique be followed to ensure that a solid and stable opening is achieved.

Continually check squareness, plumbness, alignment, and twist in the frame as wall progresses.